

SPECIFICATION OF EMULSION BITUMEN CMS

GENERAL DESCRIPTION OF EMULSION ASPHALT CMS

BITUMEN EMULSIONS CMS ARE USUALLY MADE BY PASSING THE MIXTURE OF HOT BITUMEN AND WATER PHASE BETWEEN A ROTATING DISC, CONE OR WHEEL AND A STATOR. IN THE EMULSIFICATION PROCESS, HOT BINDER IS MECHANICALLY SEPARATED INTO MINUTE GLOBULES AND DISPERSED IN WATER TREATED WITH A SMALL QUANTITY OF EMULSIFYING AGENT. THE WATER IS CALLED THE CONTINUOUS PHASE AND THE GLOBULES OF BINDER ARE CALLED THE DISCONTINUOUS PHASE. BY PROPER SELECTION OF AN EMULSIFYING AGENT AND OTHER MANUFACTURING CONTROLS, EMULSIFIED ASPHALTS ARE PRODUCED IN SEVERAL TYPES AND GRADES:

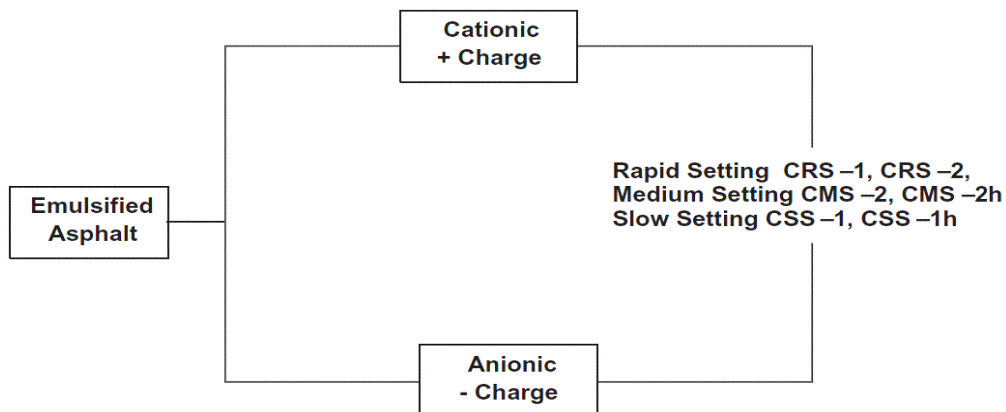

BY CHOICE OF EMULSIFYING AGENT, THE EMULSIFIED ASPHALT MAY BE: (1) ANIONIC - BINDER GLOBULES ARE ELECTRO-NEGATIVELY CHARGED. (2) CATIONIC - BINDER GLOBULES ARE ELECTRO-POSITIVELY CHARGED. ALSO, BY VARIATION IN MATERIALS AND MANUFACTURE EMULSIFIED ASPHALTS OF BOTH ANIONIC AND CATIONIC TYPES ARE MADE IN SEVERAL GRADES. SOME OF THESE GRADES AND THEIR USES ARE: (1) ANIONIC - NON -VIRGINIA GRADES RS-2

TACK AND SEAL COAT, SS-1H SLOW SET SLURRY AND TACK, (2) CATIONIC - VIRGINIA GRADES CRS-2 TACK AND SEAL COAT, CRS-1 TACK, CRS-1H TACK CSS-1H TWO TYPES FOR SLURRY (RAPID SET AND SLOW SET) AND TACK; CMS-2 PRIME, TACK, SEAL, AND COLD MIX. (CONTAINS 7-12% SOLVENT) BECAUSE PARTICLES HAVING A LIKE ELECTROSTATIC CHARGE REPEL EACH OTHER, ASPHALT GLOBULES ARE KEPT APART UNTIL THE EMULSION IS DEPOSITED ON THE SURFACE OF THE SOIL OR AGGREGATE PARTICLES. EMULSIFIED ASPHALTS CAN BE USED WITH COLD AS WELL AS HEATED AGGREGATES, AND WITH AGGREGATES THAT ARE DRY, DAMP, OR WET.

ADVANTAGE OF USING EMULSION ASPHALT CMS

NO PETROLEUM SOLVENT REQUIRED TO LIQUEFY
LITTLE OR NO HYDROCARBON EMISSIONS
IN MOST CASES, USED WITH NO ADDITIONAL HEAT
THE ABILITY TO COAT DAMP AGGREGATE
CAN USE COLD MATERIALS AT REMOTE SITES
WIDE VARIETY OF EMULSION TYPES AVAILABLE TODAY

APPLICATION OF EMULSION BITUMEN CMS

THE ADVANTAGES OF ASPHALT EMULSIONS CMS ARE RELATED TO THEIR CHEMICAL AND PHYSICAL MAKEUP, THESE ADVANTAGES LEAD DIRECTLY TO THE APPLICATIONS TO THE APPLICATIONS IN WHICH EMULSIONS ARE USED.

1. SEALING (CRS-1, CRS-2, M-80, VPRIME, PRECOATING EMULSION)
2. SLURRY SURFACING (CQS, CQS-1H, LMCQS, MICROSYSTEMS)
3. PATCHING/CRACKFILLING (CSS, CSS-R, CMS, CMS-R, SS-1)
4. FOG SEAL (SS-1, CSS, CSS-R, CMS, CMS-R)

5. COLD MIX (CMS, CMS-R, SPECIALTY EMULSIONS)
6. TACK COATING (CRS-1, CSS, SS-1, SPECIALTY EMULSIONS).
7. DUST LAYING (CSS,SS-1, SPECIALTY EMULSIONS)
8. STABILIZATION/RECYCLING. (CSS, CMS, SPECIALTY EMULSIONS).
9. WATERPROOFING/ROOFING/HOME. (SPECIALTY EMULSIONS).
10. AGRICULTURE. (SS-1, CMS, SPECIALTY EMULSIONS).

PACKING OF EMULSION BITUMEN CMS

PACKING OF EMULSION BITUMEN CMS IS IN NEW THICK STEEL DRUM ON PALLET TO PREVENT ANY LEAK INSIDE OF CONTAINER ALSO BULK IN BITUTAINER AND TANKER.

GUARANTY/WARRANTY OF EMULSION ASPHALT CMS

ATDM GUARANTY THE QUALITY OF EMULSION CMS WITH ARRANGEMENT OF INTERNATIONAL INSPECTOR TO CHECK QUALITY AND QUANTITY OF THE BITUMEN ON EACH SHIPMENT DURING THE LOADING TO VESSEL AND CONTROLLING THE PRODUCTION BY QC TEAM VIA BATCH TEST REPORT BEFORE SHIPPING. ATDM GUARANTY THE QUALITY TO MEET WITH ASTM/EN 15322:2009

ANALYSIS OF BITUMEN CMS

PROPERTY	UNIT	SPEC.	METHOD
Kinematic Viscosity 50°C	Centistokes (CST)	50-450	ASTM D2170
Residue on Sieving, 600 Micron IS	Mass Percentage (%)	0.1 max	ASTM D244
Storage stability after 24 hours	Percentage (%)	2 max	ASTM D244
Binder Residue by Evaporation	Percentage (%)	65 min	ASTM D244
Setting Time	Minutes (')	30	ASTM D244
Penetration, 50 °C	1/10 Millimeters (mm)	40-90	ASTM D5

OUR APPROVALS

